

INT69 B1® Diagnose

INT69 B1® Diagnose

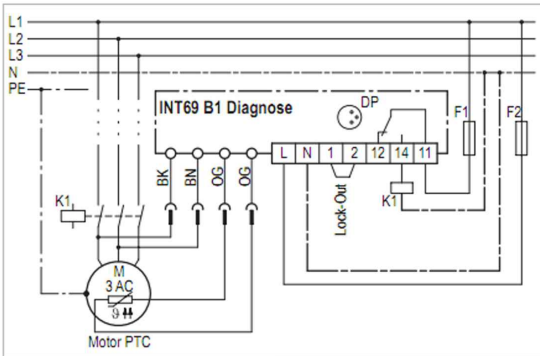

INT69 B1 Diagnose



Wiring diagram

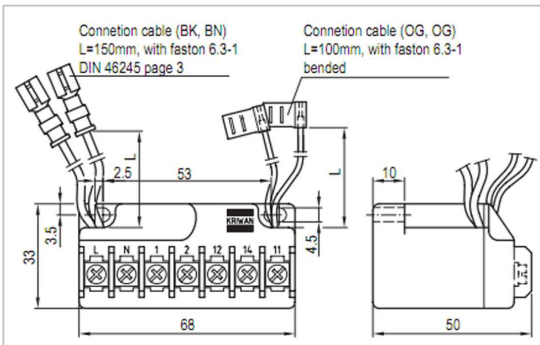

⚠ The mounting, maintenance and operation are to be carried out by an electrician. The valid European and national standards for connecting electrical equipment and cooling installations have to be observed. Connected sensors and connection lines that extend from the terminal box have to feature at least a basic insulation.

Order data

INT69 B1 Diagnose (AC 115-230V)	22 A 414 S81
INT69 B1 Diagnose (AC 24V)	31 A 414 S81
Accessories and application information	see www.kriwan.com

Application

The motor protector INT69 B1 Diagnosis is a further development of the reliable KRIWAN motor protectors. Its supplementary flexible-response protective functions help to improve the availability and extend the service life of a refrigeration system.

The INT69 B1 Diagnosis automatically saves operational and error data in a non-volatile memory. This data can be retrieved on a PC and analysed for diagnosis. The full scope of the diagnosis is achieved by using a KRIWAN-specific AMS sensor.

This motor protector is mainly employed on small and medium semi-thermal piston compressors.

Functional description

The temperature monitoring of the motor winding is done with two evaluation processes:

- **Static:** Switch-off is immediate if the nominal response temperature of the built-in AMS or PTC sensors is reached.
- **Dynamic:** If the temperature increases unusually quickly, the motor is switched off immediately even if the temperature is still far below the nominal response temperature. This prevents excess temperatures from occurring.

A short circuit at the AMS or PTC input also leads to a switch-off. If the lock-out bridge is installed, errors (with the exception of short circuit) always lead to a locked switch-off.

Restarting after locking only after reset.

If the lock-out bridge is not inserted, the compressor can be restarted after it cools down or the error is rectified and a subsequent reset delay. A network restart has to be carried out after the lock-out bridge has been changed.

For operation in the specified manner, the supply voltage has to be on permanently on the INT69 B1 Diagnosis.

Technical specifications

Supply voltage	AC 50/60Hz 115-230V ±10% 3VA
- 22 A 414 ...	AC 50/60Hz 24V ±10% 3VA
- 31 A 414 ...	
Permitted ambient temperature	-30...+70°C
Temperature measuring circuits	
- Type	1-2 AMS sensors in series alternative 1-9 PTC acc. to DIN 44081, DIN 44082 in series
- $R_{25, total}$	<1.8kΩ
- $R_{trip, static}$	4.5kΩ ±20%
- R_{reset}	2.75kΩ ±20%
- Max. length connection line	30m
Short circuit monitoring system PTC	Typically <30Ω
input, operating recognition motor	
- Lower limit	AC 100V at 20Hz to 175V at 90Hz
- Upper limit	AC 460V ±15%
Operation with frequency converters	Suitable
Reset delay	
- Motor temperature static	1min ±12s
- Motor temperature dynamic	5min ±1min
Resetting the lock or the reset delay	Main reset >5 sec. only possible if there is no error current
Relay	
- Contact	AC 240V 2,5A C300 at least AC/DC 24V 20mA
- Mechanical service life	Approx. 1 million switching cycles
Interface	Diagnose port (DP)
Protection class acc. to EN 60529	IP00
Connection type	Flat plug sleeves (PTC, operating recognition) screw terminals
Housing material	PA glass-fibre-reinforced
Mounting	Screw mounted
Dimensions	Refer to dimensions in mm
Weight	Approx. 200g
Check base	EN 61000-6-2, EN 61000-6-3 EN 61010-1 Overvoltage category II Pollution level 2
Approval	UL File No. E75899 cUR _{us}

Technical changes reserved

