

# INT69 KFY2® Diagnose

## INT69 KFY2® Diagnose

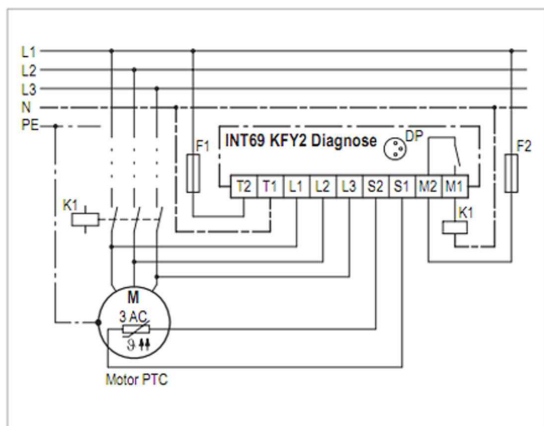

INT69 KFY2 Diagnose



Wiring diagram

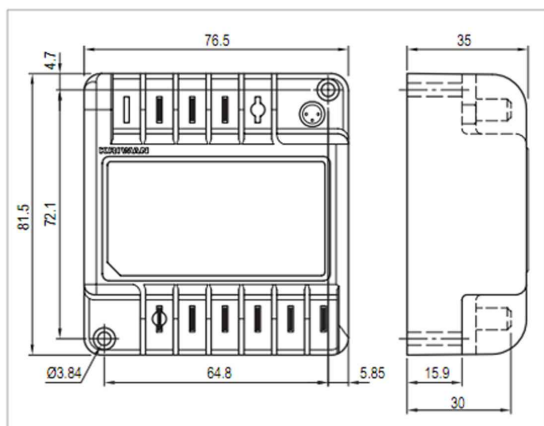

Dimensions in mm

### Application

The compressor protection INT69 KFY2 Diagnose is a further development of the reliable KRIWAN motor protectors. Additional inputs for the phase monitoring as well as supplementary flexible-response protective functions help to improve the availability and extend the service life of a refrigeration system.

The INT69 KFY2 Diagnose automatically saves operational and error data in a non-volatile memory. This data can be retrieved on a PC and analysed for diagnosis. The full scope of the diagnosis is achieved by using a KRIWAN-specific AMS sensor.

This motor protector is mainly employed on compressors which are qualified acc. to IEC/EN 60335 and of which the motor's direction of rotation is essential for the function.

### Functional description

The temperature monitoring of the motor winding is done with two evaluation processes:

- **Static:** Switch-off is immediate if the nominal response temperature of the built-in AMS or PTC sensors is reached.
- **Dynamic:** If the temperature increases unusually quickly, the motor is switched off immediately even if the temperature is still far below the nominal response temperature. This prevents excess temperatures from occurring.

A short circuit at an AMS or PTC input also leads to a switch-off. A short cycling leads to a reset delay.

After expiration of the reset delay and elimination of the error or cooldown, the compressor can be restarted, restarting after locking only after reset.

The phase monitoring of the motor voltage is active 1s after the start of the motor. The correct phase sequence is monitored for 5s, the phase failure is monitored for the total motor running time. If a wrong phase sequence is detected, the motor protector will lock switch off, if there is a phase failure then a switch-off takes place.

After motor stop, the phase monitoring is deactivated for approx. 5s to prevent unintended locking due to brief reverse running of the compressor.

For operation in the specified manner, the supply voltage has to be on permanently on the INT69 KFY2 Diagnose.

**!** The mounting, maintenance and operation are to be carried out by an electrician. The valid European and national standards for connecting electrical equipment and cooling installations have to be observed. Connected sensors and connection lines that extend from the terminal box have to feature at least a basic insulation.

See back side for further specifications

## INT69 KFY2® Diagnose

## INT69 KFY2® Diagnose

## Technical specifications

Supply voltage	115-230V ~ 50Hz ±10% 3VA 120-240V ~ 60Hz ±10% 3VA 24V ~ 50/60Hz ±10% 3VA
- 22 A 650 S80	
- 31 A 650 S80	
Permitted ambient temperature	-30...+70°C
Temperature measuring circuits	
- Type	1-2 AMS sensors in series alternative 1-9 PTC sensors acc. to DIN 44081, DIN 44082 in series
- $R_{25, total}$	<1.8kΩ
- $R_{trip, static}$	4.5kΩ ±20%
- $R_{reset}$	2.75kΩ ±20%
- Max. length connection line	30m
Short circuit monitoring system PTC	Typically <30Ω
Motor voltage	3 AC 50/60Hz 200-690V ±10%
Phase monitoring	
- Phase sequence	Active about 1s after motor start for about 5s
- Phase failure	Active about 1s after the motor start until the motor stop After motor stop for approx. 5s
- Inactive	Not suitable
Operation with frequency converters	
Switching frequency overstepping	3 switch-offs in 30s
Reset delay	
- Motor temperature static	30min ±5min
- Motor temperature dynamic	30min ±5min
- Switching frequency overstepping	5min ±1min
- Incorrect phase sequence	Locked
- Phase failure	
1.-9./24h	5min ±1min
10./24h	Locked
Resetting the lock or the reset delay	Main reset >5s only possible if there is no error current
Relay	
- Contact (22 A 650 S80)	AC 240V 2.5A C300 at least AC/DC 24V 20mA
- Contact (31 A 650 S80)	AC 240V 2.5A C300 at least AC/DC 100mV 0.5mA
- Mechanical service life	Approx. 1 million switching cycles
Interface	Diagnose port (DP)
Protection class acc. to EN 60529	IP00
Connection type	6.3mm flat plugs
Housing material	PA glass-fibre-reinforced
Mounting	Screw mounted
Dimensions	Refer to dimensions in mm
Weight	Approx. 200g
Check base	IEC/EN 60335, IEC/EN 60730 EN 61000-6-2, EN 61000-6-3 EN 61010-1 Overvoltage category II Pollution level 2
Approval	UL File no. E75899 cUR <sub>UL</sub> VDE certification no. 40022017

## Order data

INT69 KFY2 Diagnose (AC 115-230V)	22 A 650 S80
INT69 KFY2 Diagnose (AC 24V)	31 A 650 S80
Accessories and application Information	see www.kriwan.com

Technical changes reserved