

INT69 TM[®] Diagnose

INT69 TM[®] Diagnose

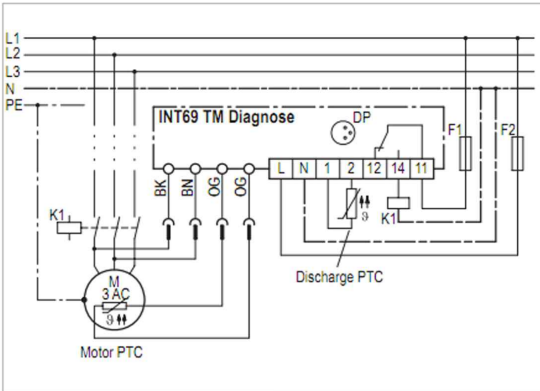

INT69 TM Diagnose



Wiring diagram

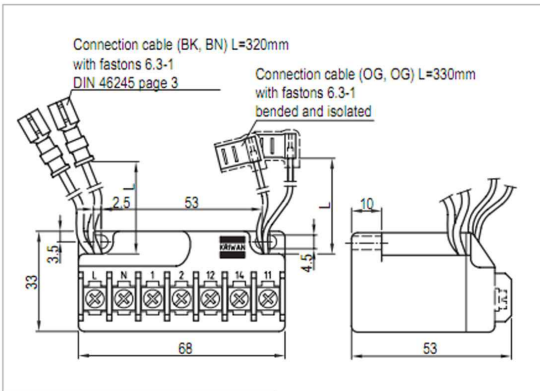

Dimensions in mm

⚠ The mounting, maintenance and operation are to be carried out by an electrician. The valid European and national standards for connecting electrical equipment and cooling installations have to be observed. Connected sensors and connection lines that extend from the terminal box have to feature at least a basic insulation.

Order data

INT69 TM Diagnose	22 A 490
Accessories and application information	see www.kriwan.com

Application

The compressor protection INT69 TM Diagnose is a further development of the reliable KRIWAN motor protectors. An additional input for a discharge gas sensor and its supplementary flexible-response protective functions help to improve the availability and extend the service life of a refrigeration system.

The INT69 TM Diagnose automatically saves operational and error data in a non-volatile memory. This data can be retrieved on a PC and analysed for diagnosis. The full scope of the diagnosis is achieved by using a KRIWAN-specific AMS sensor.

This motor protector is mainly employed on medium and large semi-thermal piston compressors.

Functional description

The temperature monitoring of the motor winding is done with two evaluation processes:

- **Static:** Switch-off is immediate if the nominal response temperature of the built-in AMS or PTC sensors is reached.
- **Dynamic:** If the temperature increases unusually quickly, the motor is switched off immediately even if the temperature is still far below the nominal response temperature. This prevents excess temperatures from occurring.

The discharge gas temperature is evaluated statically.

A short circuit at an AMS or PTC input also leads to a switch-off. A short cycling leads to a reset delay. If no discharge gas sensor is installed, a 100 ohm resistor has to be installed at the input.

After cooldown or elimination of the error and a subsequent reset delay, the compressor can be restarted.

For operation in the specified manner, the supply voltage has to be on permanently on the INT69 TM Diagnose.

Technical specifications

Supply voltage	AC 50/60Hz 115-230V ±10% 3VA
Permitted ambient temperature	-30...+70°C
Temperature measuring circuits	1-2 AMS sensors in series alternative 1-9 PTC acc. to DIN 44081, DIN 44082 in series
- Type	<1.8kΩ 4.5kΩ ±20% 2.75kΩ ±20%
- R _{25, total}	30m
- R _{trip, static}	
- R _{reset}	
- Max. length connection line	
Short circuit monitoring system	Typically <30Ω
PTC	
Input, operating recognition motor	
- Lower limit	AC 100V at 20Hz up to 175V at 90Hz
- Upper limit	AC 460V ±15%
Operation with frequency converters	Suitable
Switching frequency overstepping	3 switch-offs in 30s
Reset delay	
- Motor temperature static	5min ±1min
- Motor temperature dynamic	5min ±1min
- Discharge gas temperature	10min ±2min
- Switching frequency overstepping	5min ±1min
Reset of reset delay	Main reset >5 sec. only possible if there is no error current
Relay	
- Contact	AC 240V 2.5A C300 at least AC/DC 24V 20mA
- Mechanical service life	Approx. 1 million switching cycles
Interface	Diagnose port (DP)
Protection class acc. to EN 60529	IP00
Connection type	Flat plug sleeves (PTC, operating recognition) screw terminals
Housing material	PA glass-fibre-reinforced
Mounting	Screw mounted
Dimensions	Refer to dimensions in mm
Weight	Approx. 200g
Check base	EN 61000-6-2, EN 61000-6-3 EN 61010-1
Approval	Overvoltage category II Pollution level 2 UL File No. E75899 cURus

Technical changes reserved