

INT279 LX® Level monitor



INT279 LX

Application

The optical level monitoring INT279 LX is employed for contactless single point measurement of fluid levels, e.g. on compressors, pumps, tanks, etc. The solution consists of a screw-in part and an evaluation unit. The screw-in part for optical level monitoring is permanently built-in at the measuring point. The electronic evaluation unit can be mounted or replaced without opening the circuit of the medium to be monitored.

Functional description

Light pulses of the device are refracted in fluids and reflected in gaseous environments. This allows the INT279 LX to detect the fluid level reliably.

Level monitoring begins 3s after supply voltage has been connected. Time-delayed reaction prevents switching errors that can be caused by temporary fluctuations of the fluid.

If the level is too high or if there is an error, the relay drops out.

Once the correct level has been reached again or the error has been rectified, the relay energises again.

The potential-free, change-over contact can be looped into a safety circuit without an auxiliary relay.

An integrated own monitoring system ensures high reliability; an installation check monitors the proper assembly.

A built-in LED signals the current status (see flash code).

- Level good
- Level missing
- Internal error, voltage supply too low or faulty assembly

Installation instructions

1. Ensure cleanliness of thread and glass of the screw-in part.
2. Mount evaluation unit into the screw-in part. The cable outlet has to point downwards here.
3. Tighten the coupling ring hand tight.

The mounting, maintenance and operation are to be carried out by an electrician. The valid European and national standards for connecting electrical equipment have to be observed.

See back side for further specifications

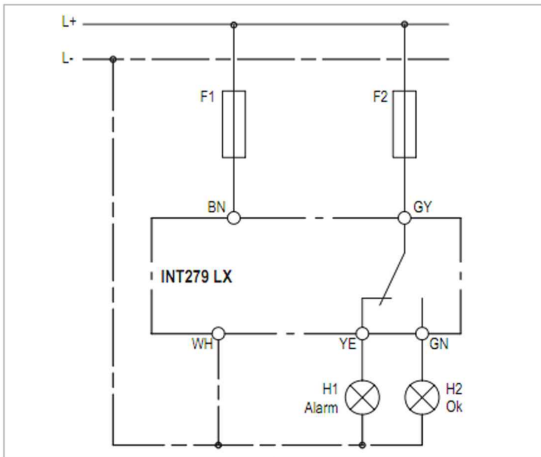

Wiring diagram

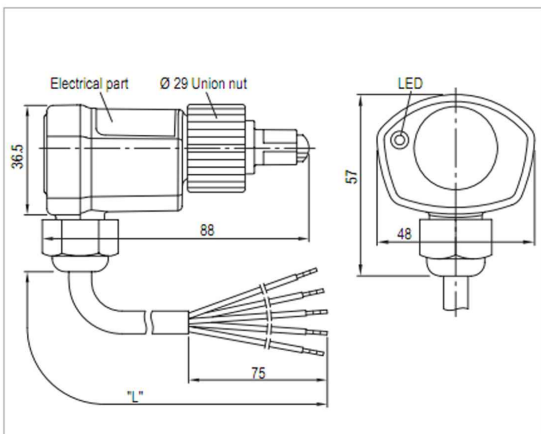

Dimensions in mm

Technical changes reserved



INT279 LX®

INT279 LX® Level monitor

Technical specifications

Supply voltage	AC/DC 50/60Hz 24V ±10% 3VA
Permitted ambient temperature	-30...+60°C
Medium temperature	Max. +120°C (<1h) Max. +100°C
Permitted rel. humidity	10-95% r. h. no condensation
Switch delay	
- After applying the supply voltage	3s ±1s
- Level missing or fault	5s ±2s
- Level good and no fault	5s ±2s
Relay	
- Contact	AC 240V 2.5A C300 at least AC/DC 24V 20mA
- Mechanical service life	Approx. 1 million switching cycles
Protection class acc. to EN 60529	IP54 In mounted condition
Connection type	Cable LIYCY 5 x 0.75mm ² L=10m
Housing material	PA glass-fibre-reinforced
Mounting	Union nut (torque max. 10Nm)
Dimensions	Refer to dimensions in mm
Weight	Approx. 1,1kg
Check base	EN 61000-6-2, EN 61000-6-3 EN 61010-1 Overvoltage category II Pollution level 2

Order data

INT279 LX Level monitor	20 S 479 S21
Accessories and application information	see www.kriwan.com