



KLIXON | 15HM SERIES MOTOR PROTECTORS

Hermetically Sealed Single Phase
On Winding Protection

PRODUCT OVERVIEW

The Klixon® 15HM Series hermetically sealed single phase on-winding motor protectors are a new generation product designed to meet the demands of tomorrow's compressors.

Features & Benefits

- High Reliability – 2 contact ratings
- Optional start winding protection
- Compact and rugged construction
- Meet rotary compressor high side pressure requirements
- Application range – 1 to 5 HP

Product Description

The 15HM family of motor protectors can be applied to unitary air conditioning and heat pump compressors ranging from 1 to 5 HP. They may also be used in commercial motors which must function in destructive or corrosive environments. Its compact and rugged design make it resistant to mechanical shock and suitable for installation directly on motor windings.

Line Break Operation

Klixon® 15HM motor protectors are line break automatic reset controls which are wired in series with and mounted on the motor windings. These protectors track winding temperatures and respond to changes in line current to afford protection against the wide variety of overload conditions listed below:

- Running overload
- High/low voltage locked rotor
- Loss of refrigerant charge
- Shorted capacitor
- High discharge temperature

15HM Code System

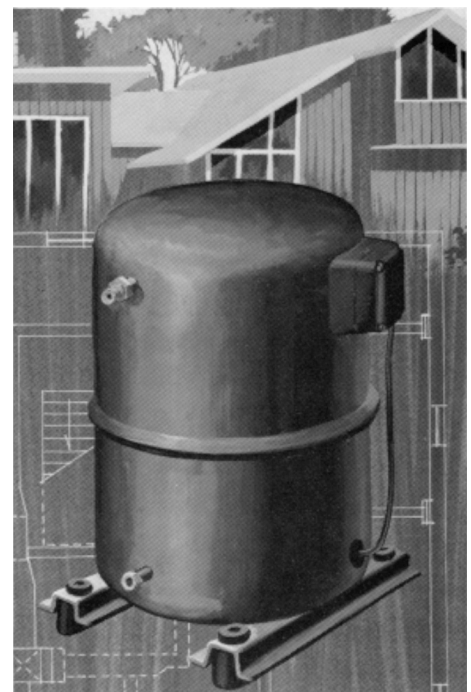
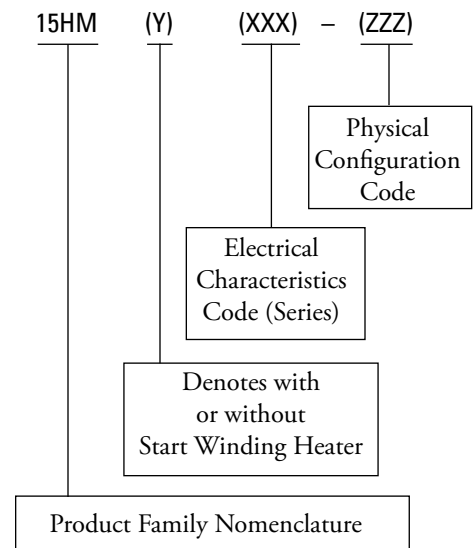

KLIXON | 15HM SERIES MOTOR PROTECTORS

Hermetically Sealed Single Phase On-Winding Protection

Protector Ratings

Series	Product Family	Start Winding	Line Voltage	Locked Rotor Current	HP Range
300	13XX	Yes	230V	*100 Amp	*1 - 3 1/2
	23XX	No			
600	16XX	Yes	230V	*140 Amp	*3 1/2 - 5
	26XX	No			

*To be used as a guide for selection only, consult factory for specific life test data.

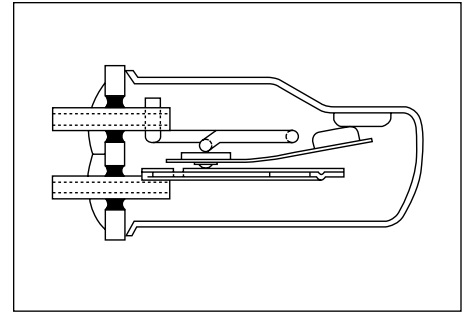

Dimensions (Metric Dimensions in Parenthesis)

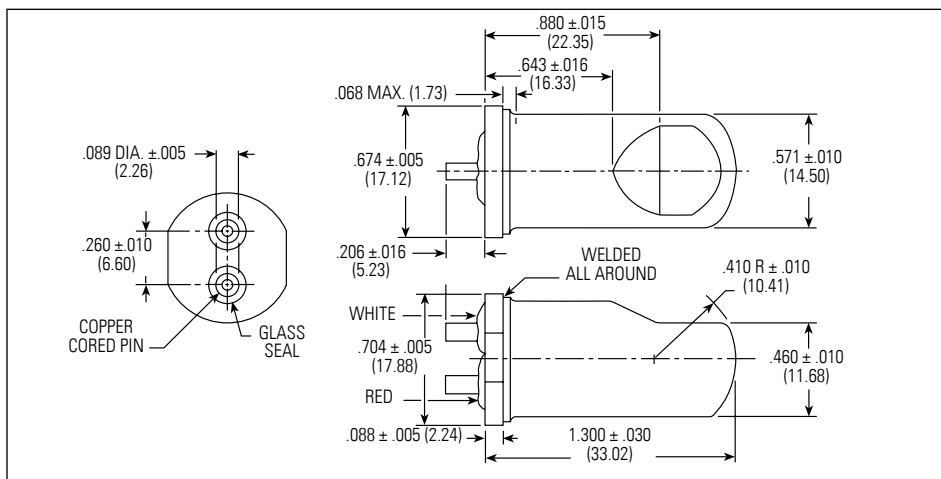

Specifications

Open Temperature 90°C - 150°C
in 5°C increments
Tolerance ±5°C
Open ±9°C Close

Epoxy protected glass seals
Optional terminations
UL/Canadian UL - E15962
DEKRA (ENEC) - 2018218.05
CQC - CQC03002007249

Circuit Diagram

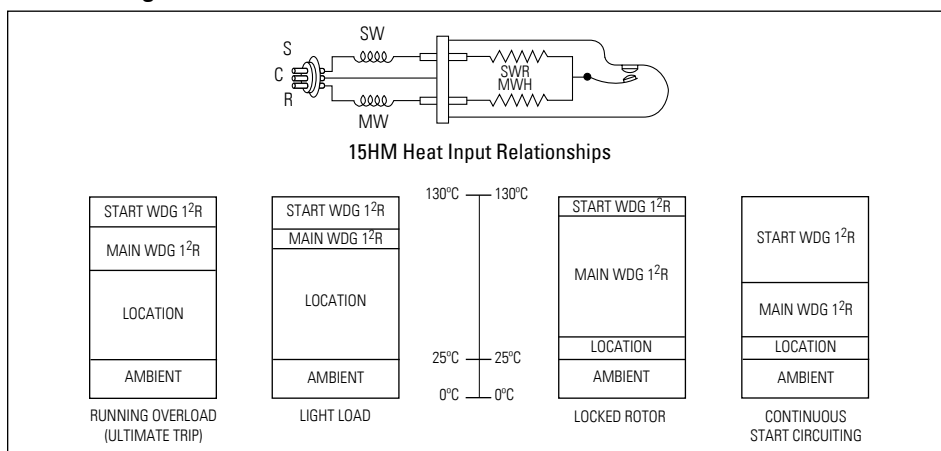

The World Depends on Sensors and Controls



Important Notice: Sensata Technologies (Sensata) reserves the right to make changes to or discontinue any product or service identified in this publication without notice. Sensata advises its customers to obtain the latest version of the relevant information to verify, before placing any orders, that the information being relied upon is current. Sensata assumes no responsibility for infringement of patents or rights of others based on Sensata applications assistance or product specifications since Sensata does not possess full access concerning the use or application of customers' products. Sensata also assumes no responsibility for customers' product designs.