

Thermal cut-out
Thermostat

K

1AV
1AT

Applications

- Fuel oil burner
- Welding- / soldering equipment
- Ironing machines
- Electric cookers

Benefits

- Response sensitivity
- Various types
- Robust design
- High temperatures up to 450°C

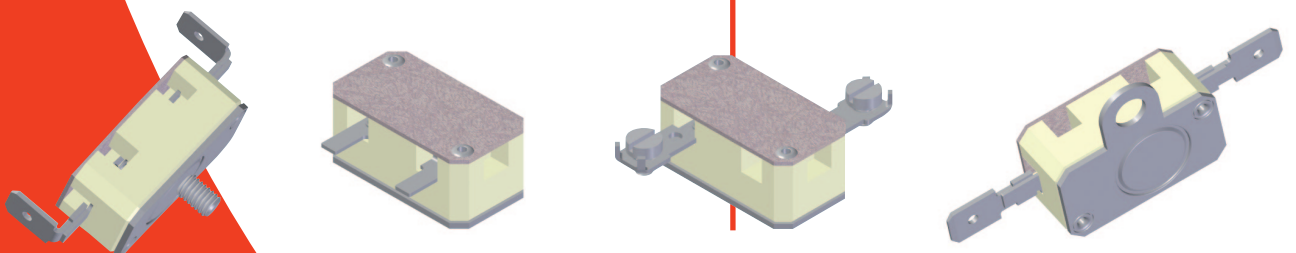
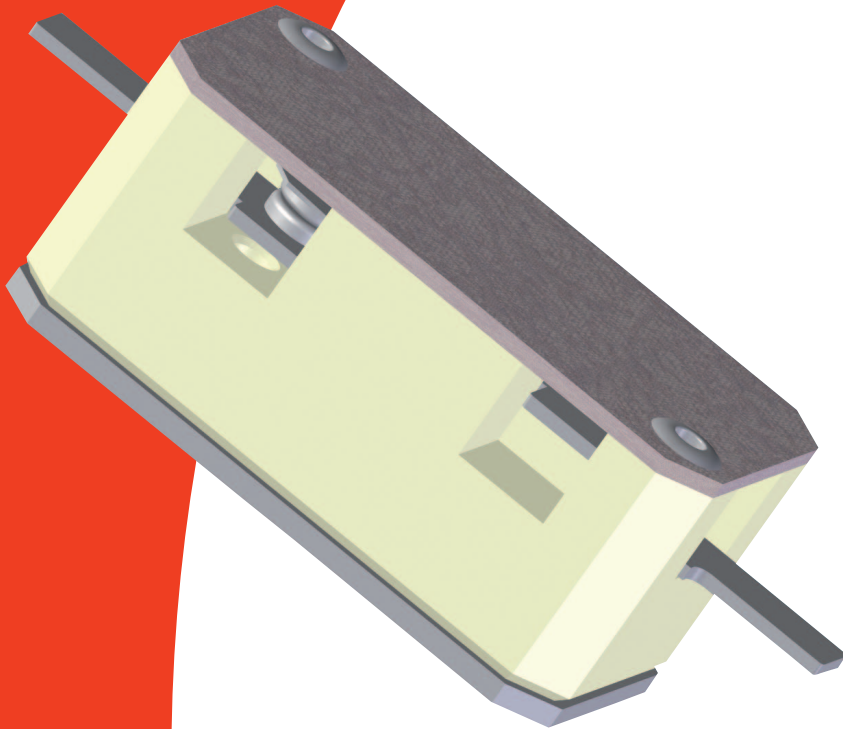

MICROTHERM

上海坦发秋尔
WWW.TPQE.COM
021-62041958



Microtherm International Cooperation

Technical data

ratings		control type	
		K1AV	K1AT
function		automatic	
version		normally closed	normally open
rated current at 230 V 50 / 60 Hz (cos ϕ 0,95)		10 A	
rated current at 400 V 50 / 60 Hz (cos ϕ 0,95)		6 A	
switching cycles		10,000	
temperature range T _a (steps in 5 K)		200°C - 450°C	
tolerances		± 5%	± 10%
feature of automatic action		1.B	
contact resistance		< 50 mΩ	
hysteresis		100K ± 20K	
degrees of protection provided by enclosures (EN 60529)		IP00	
suitable for use in protection class		I	
approval	VDE 	EN 60730-1 / -2-9	-

Standard type

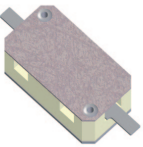
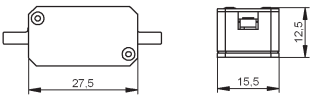
type	nc	no	illustration	drawing dimensions (mm)	technical description	approval ¹⁾
K1A	V	T			cover micanite housing ceramic bottom plate steel	VDE

Terminals

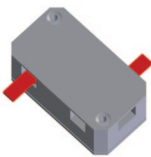
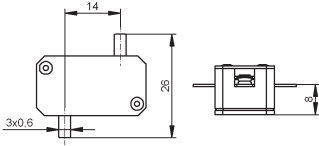
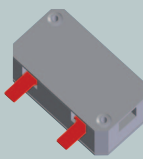
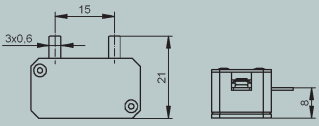
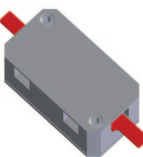
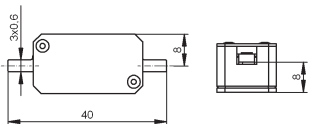
code	illustration	drawing dimensions (mm)	technical description	approval ¹⁾
A160			welding terminals, steel	VDE
A170			welding terminals, steel	VDE
A180			welding terminals, steel	VDE

¹⁾ VDE approval is only valid for type K1AV

code	illustration	drawing dimensions (mm)	technical description	approval ¹⁾
A161 (0°) A162 (90°)			terminals 6.3 x 0.8, steel, also available: angle 90 deg T _a max 350°C	VDE
A171 (0°) A172 (90°)			terminals 6.3 x 0.8, steel, also available: angle 90 deg T _a max 350°C	VDE
A181 (0°) A182 (90°)			terminals 6.3 x 0.8, steel, also available: angle 90 deg T _a max 350°C	VDE
A163 (0°) A164 (90°)			screw terminals, steel, also available: angle 90 deg T _a max 350°C	VDE
A173 (0°) A174 (90°)			screw terminals, steel, also available: angle 90 deg T _a max 350°C	VDE
A183 (0°) A184 (90°)			screw terminal, steel, also available: angle 90 deg T _a max 350°C	VDE
A168			lead L551, welded	VDE
A178			lead L551, welded	VDE
A188			lead L551, welded	VDE

¹⁾ VDE approval is only valid for type K1AV

lead L551: UL style 5107, 600V, max. 450°C, insulation glass fibre-PTFE, cross-section of conductor 1,3 mm² (AWG16) , grey, stripped 10mm

Fixings

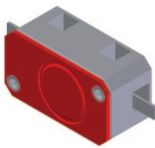
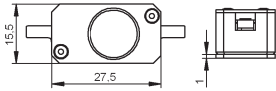
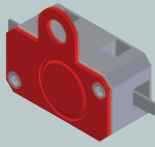
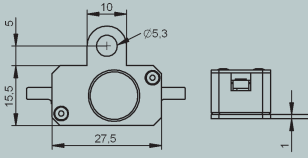
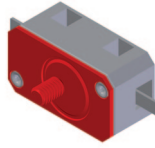
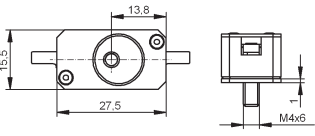
code	illustration	drawing dimensions (mm)	technical description	approval ¹⁾
B410			bottom plate, steel	VDE
B412			bottom plate with flange, steel	VDE
B413 (M4x6) B414 (M5x6)			bottom plate with stud, steel	VDE

¹⁾ VDE approval is only valid for type K1AV

Ordering and marking example

Ordering example

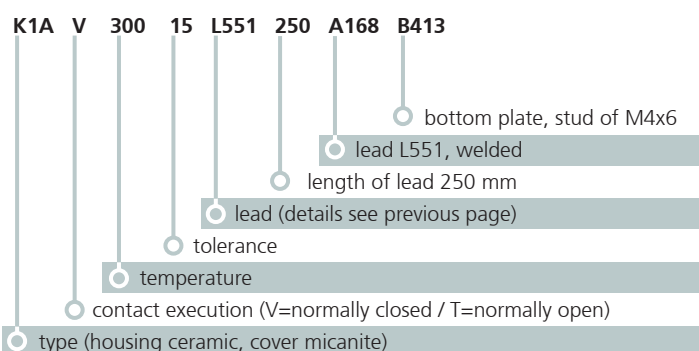

Marking

K1AV 30015	type (normally closed) response temperature (300°C), tolerance (+/- 15K)
XXXXX	production number
K1AT --123	type (normally open) drawing number
XXXXX	production number

